

# Architek

002-8068/002-8113/002-8114/002-8166/002-8169/  
002-8173/002-8174/002-8175/002-8177/002-8178/  
002-8179/002-8180/002-8181/002-8182

## INSTRUCTION MANUAL DOOR

Dear Customer,  
Thank you for purchasing this product. To ensure the best possible performance, please **READ, FOLLOW, AND KEEP THESE INSTRUCTIONS.**  
Note: Product may differ from the picture.

### MATERIALS AND TOOLS

#### FINISHING MATERIALS (NOT INCLUDED)

Rubber gloves	Paint (and primer for raw wood doors) or stain and wood conditioner
Paint brush	
Sand paper	Wood putty
Drop cloth	

#### TOOLS (NOT INCLUDED)

Hammer
Drill with bits
Screwdrivers
Safety glasses
Measuring tape

### WARRANTY

Thank you for purchasing this door. This product has been designed to the highest quality standards and is guaranteed for 12 months for domestic use against manufacturing defects from the date of purchase. This warranty does not affect your statutory rights.

The door is guaranteed if used for normal trade purposes and is valid for the original buyer only. Any warranty is deemed invalid if the door has been improperly used or subject to neglect. The product is recommended for residential and non-commercial use. No warranty applies to commercial use. Tactical Distribution is not responsible for any costs related to labour, injuries or any other loss incurred during the product installation, repair or replacement, including any indirect or consequential damages. Due to continuous product improvement, we reserve the right to change the product specifications without prior notice.

### GLOSSARY

#### Finished Opening

The resulting opening after any trim work is completed. Measure these dimensions for proper door fitting.

#### Lead Door

The panel or section without the pivoting hardware. On four-panel assemblies, these are the two that meet in the middle.

#### Pivot Door

The panel or section that contains the pivoting hardware and supports the weight of the door assembly.

### WARNINGS

- Read and fully understand ALL manufacturer's instructions before beginning. Failure to follow proper installation instructions may result in the denial of warranty claims for operational or performance problems.
- Use safe lifting techniques.
- Wear protective gear (e.g. safety glasses, gloves, ear protection, etc.).
- Operate hand/power tools safely and follow manufacturer's operating instructions.
- Heed material manufacturer's handling and application instructions.
- Store doors in a dry, well-ventilated building and on a flat and level surface.
- Do not subject interior doors to extremes of heat and/or humidity. Prolonged exposure may cause damage. Buildings where humidity and temperature are controlled provide the best storage facilities (recommended conditions 30%-50% relative humidity and 50°F to 90°F).
- Do not install doors in buildings that have wet plaster or cement unless they have been properly finished. Do not store doors in buildings with excessive moisture content - HVAC systems should be operating and balanced. Avoid sudden changes such as forced heat to dry out a building. Doors should not be delivered to the job site or installed until concrete floors, foundation, plaster or drywall are cured.
- Doors should always be handled with clean hands or while wearing clean gloves.
- Doors should be lifted and carried when being moved, not dragged across one another.
- Finish all six sides (both sides and all four edges) of the door slab, including cutouts for hardware. Failure to finish all six sides may result in the denial of warranty claims for operational or performance problems.
- If disturbing existing paint, take proper precautions if lead paint is suspected (commonly used before 1979). Your regional EPA ([www.epa.gov/lead](http://www.epa.gov/lead)) or Consumer Product Safety Commission offices provide information regarding regulations and lead protection.
- WARNING: Drilling, sawing, sanding or machining wood products generates wood dust. Use a respirator or other safeguards to avoid inhaling it.
- IF INJURY OCCURS, IMMEDIATELY SEEK MEDICAL ATTENTION!

# 1. INSPECT FINISHED OPENING, REMOVE PACKAGING AND INSPECT DOOR

## INSPECT FINISHED OPENING

- The width size specification (finished opening size) shown on the bifold packaging is 1/2" larger than the bifold set to allow for at least a 1/4" gap between the side jamb and pivot door (door secured to the floor and head jamb). Double units should have at least 1/4" gap between both side jambs and no gap between the doors that meet in the middle.
- The height size specification (finished opening size) shown on the bifold packaging is 1-1/2" larger than the bifold set to allow for the track to be installed above the door set and the lower bracket installed below the door set.

Single Bifold Set

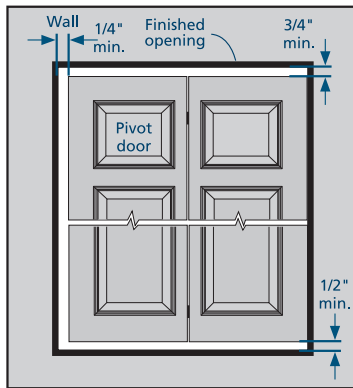

Double Bifold Set

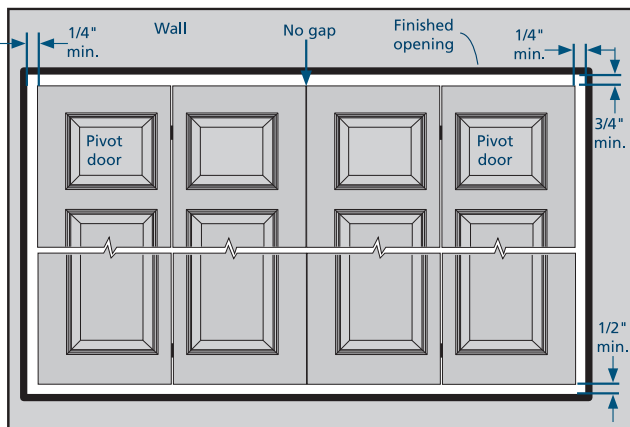

- Measure height and width of finished wall opening and verify it is no more than 1/4" larger or smaller than the stated opening size on the packaging.
- Once the door set(s) is (are) installed, there is an additional hardware adjustment of up to 3/8" to center the sets in the finished opening.
- If the finished opening is too large, filler material such as a 1" x 6" piece of pine trim can be tacked into the opening to bring it to the correct size.
- If the finished opening is too small (1/2" or less), 1-3/8" thick hollow or solid core molded and flush doors may be trimmed 1/4" on each side as necessary. Trimming any other bifold type is not recommended. For the best appearance, trim an equal amount from opposite sides. To minimize chipping, stick masking tape along the cut line to each face of the slab. Make the cuts with a fine toothed circular saw.
- If the opening is too far out of specification, or if you are not confident trimming, you can order custom sizes from our manufacturing locations to fit the finished opening, or contact a building professional for assistance.

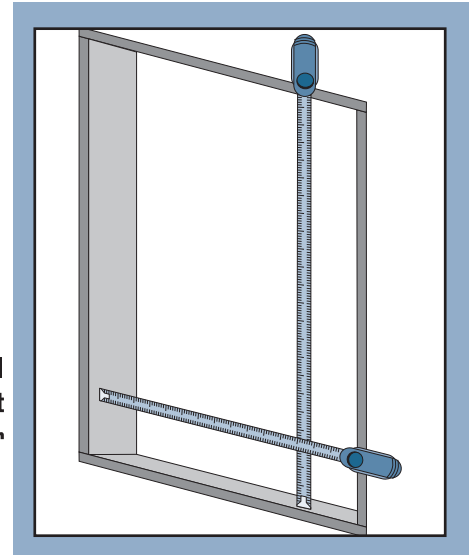

## FOR RETROFIT INSTALLATION

For retrofit installations, remove the old door and contact your local waste management entities for proper disposal or recycling of products being removed.

## REMOVE PACKAGING

Remove shipping materials such as corner covers, shipping blocks or pads.

## INSPECT DOOR

- Cosmetic damage
- Correct product (size, color, design, etc.)

## 2. IDENTIFY HARDWARE TYPE

Open the hardware pack and compare the contents to the images on this page. They do not show everything in the hardware pack, but only what is necessary to properly identify a specific type of hardware. Go to the page number for the pictured hardware type that matches the contents of the hardware pack that came with the door and follow the installation instructions.

Type A1 - Page 4

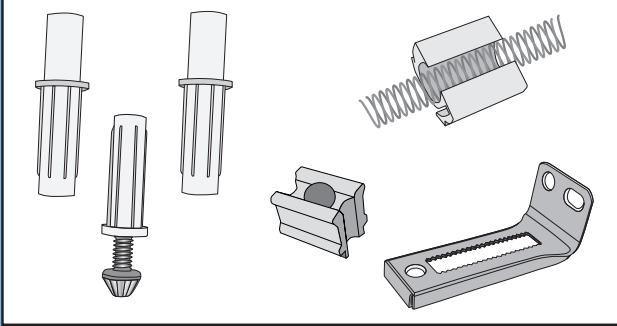

Type A2 - Page 4

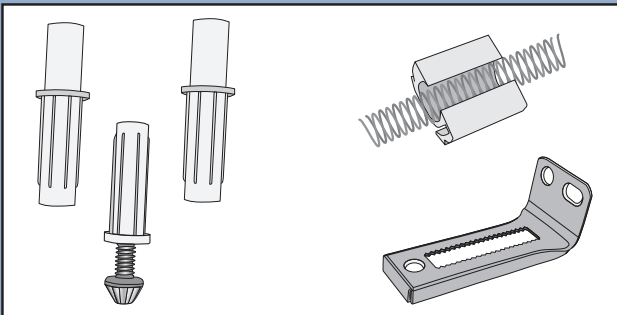

Type A3 - Page 4

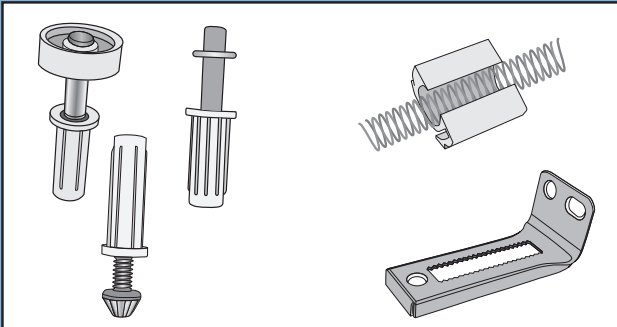

Type A4 - Page 4

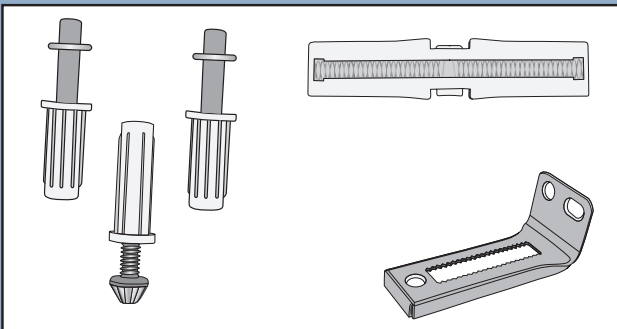

Type B - Page 5

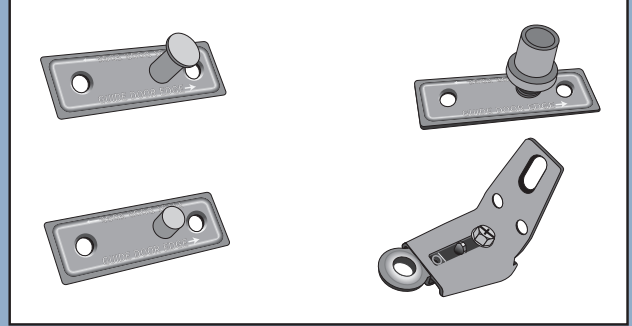

Type C - Page 6

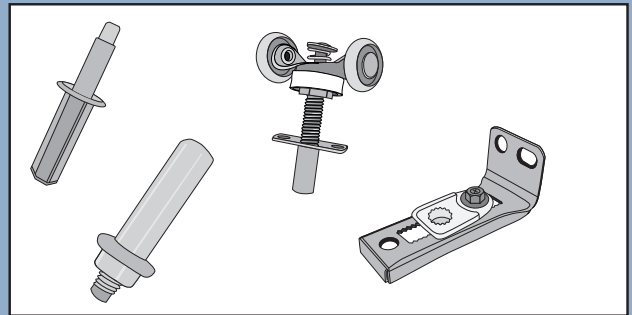

Type D - Page 7

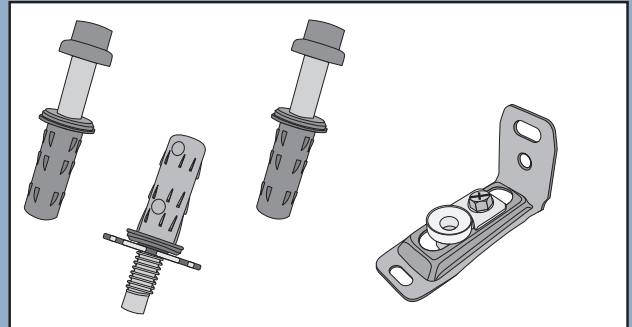

Type E - Page 8

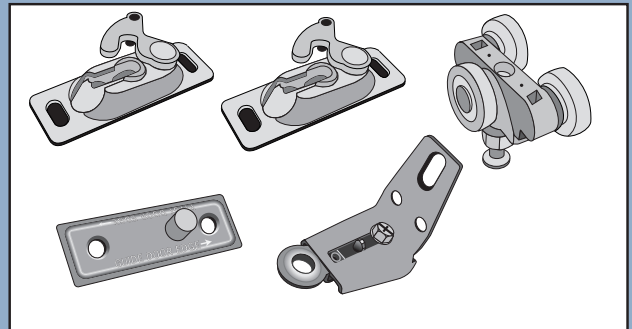

### 3. INSTALLATION FOR TYPE A1 - A4

#### PARTS INCLUDED

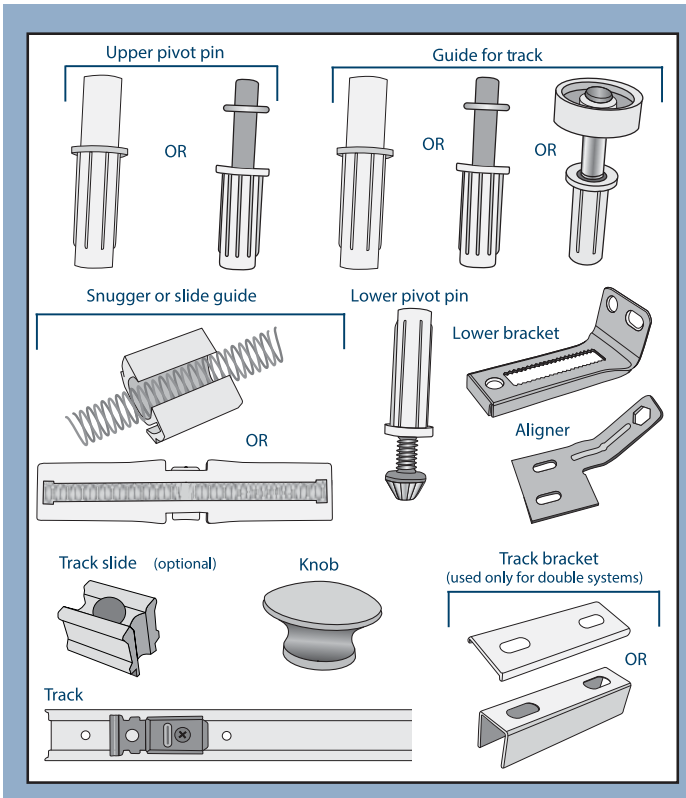

1. Using a hammer, gently tap pivot pins and guide into the pre-drilled holes in the locations shown.

2. Position overhead track in the opening with the open side down and the bracket end toward the jamb. Center the track, or allow at least 3/4" between the track and the front of the opening. If installing a double set with two tracks, insert the track bracket into the two ends where they meet in the middle and push the tracks together. The holes in the bracket should align with the holes in the tracks. Center the entire assembly side to side in the opening. Secure the track with the long pan head screws through the pre-drilled holes until snug. If installing four-panels with two tracks, use a track bracket between the two ends in the center.

3. Position the lower bracket on the floor in line with overhead track. The bottom of the bracket must rest securely on the floor or carpet. Fasten to the jamb and floor with a long flat head screw through each hole.

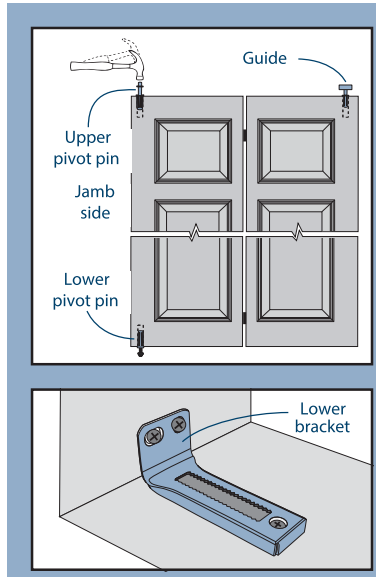

4. Place the upper pivot pin in the hole in the bracket and the guide in the track (or in the middle of the slide guide between the springs). Lift the door assembly slightly and drop the lower pin into the lower bracket slot.

5. Verify there is a 1/4" clearance between the pivot door and the jamb. Four-panel assemblies should be snug at the middle. If adjustments are necessary, door panels should be folded, in some cases removed, to gain access to the adjustment screws.

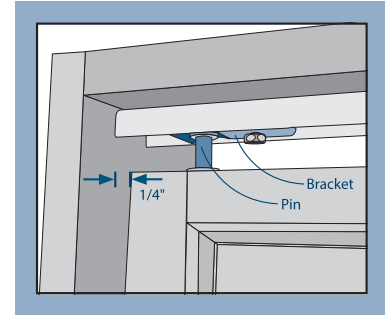

To adjust horizontally:

6. At the top, loosen the screw in the top pivot bracket and move toward or away from the jamb until there is 1/4" clearance. Re-tighten.

7. At the bottom, lift assembly and move the adjusting wheel toward or away from the jamb until doors are plumb with jamb, then lower into bracket.

To adjust vertically:

8. Lift assembly slightly until the adjustment wheel clears the slot in the lower bracket. Rotate the adjustment wheel to the left to raise doors or to the right to lower them. Be sure the teeth lock firmly into bracket when finished.

9. Snap the snugger or slide guide into the lead door end of the track as shown, or in the center of the track between guides in a four-door installation.

If using a slide guide, seat lead door guide pin between the two springs in the guide as shown.

SKIP to section 8. "COMPLETE INSTALLATION."

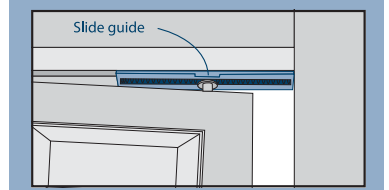
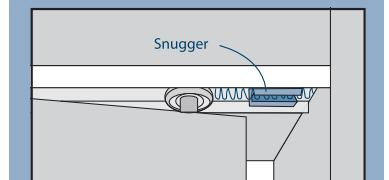
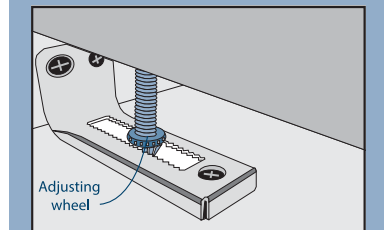
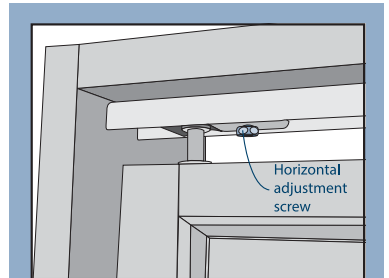

## 4. INSTALLATION FOR TYPE B

### PARTS INCLUDED

- |                    |                      |
|--------------------|----------------------|
| A. Upper pivot pin | F. Lower bracket     |
| B. Guide for track | G. Aligner           |
| C. Snugger         | H. Track             |
| D. Knob            | I. Adjustment wrench |
| E. Lower pivot pin | Screws (not shown)   |

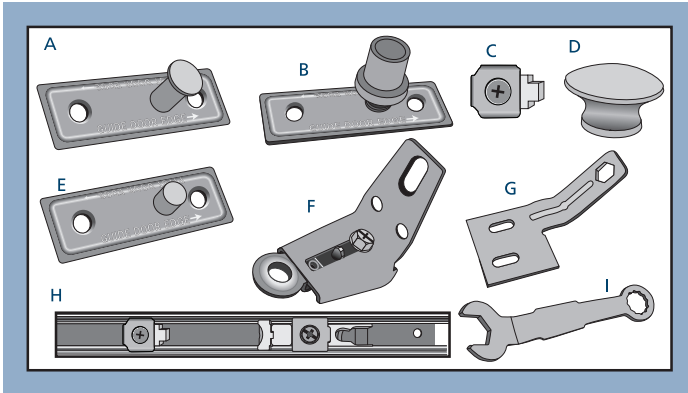

1. Position the guide, upper pivot pin and lower pivot pin on the door assembly in the locations and orientations shown.
2. Measure in 5/8" from the end of each panel and center each pin on the panel.
3. Secure with a 1" flat head screw through each hole.
4. Position overhead track in the opening with the open side down and the bracket end toward the jamb. Allow 3/4" between the front of the opening and the track and drive the 1-1/4" pan head screws through the pre-drilled holes until snug. Position the lower bracket on the floor in line with overhead track. Fasten to the jamb with a 1-1/4" flat head screw through only the middle of the top slotted hole.

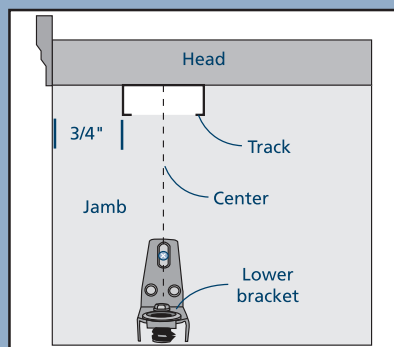
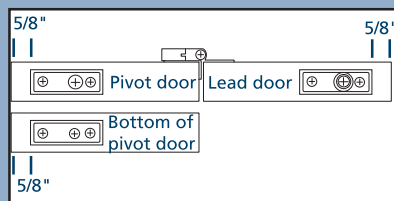
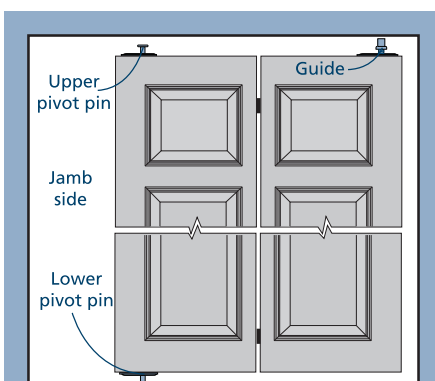

5. Unlock the track pivot latch by pulling the latch away from the jamb. With the door assembly folded, place the guide in the track and then position the upper pivot pin next to the track pivot. Slide the pin away from the jamb into the track pivot. Slide the latch toward the jamb to lock the pivot pin in place. Verify the pin is secure.

6. On the bottom, depress the arm on the lower bracket and insert the lower pivot pin. If installing a four-door system, repeat for the other assembly. Check positioning and operation.

To adjust horizontally:

7. At the top, loosen the screw in the top pivot bracket and move toward or away from the jamb until there is 1/4" clearance. Re-tighten. Repeat the process for the lower bracket.

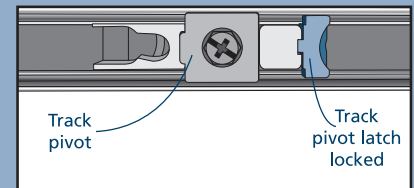
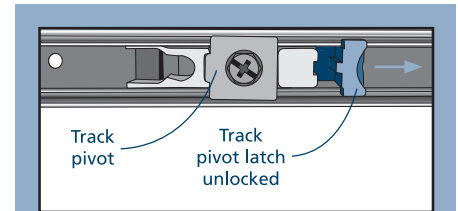

To adjust vertically:

8. There should be a slight gap between the lower pin and the bracket. If there is no gap or the gap is too large and allows the pin to come out of the bracket, loosen the single screw in the bracket and adjust up or down until there is a small gap and the pin is engaged in the bracket. When the bracket is properly adjusted, install the remaining two screws and tighten.

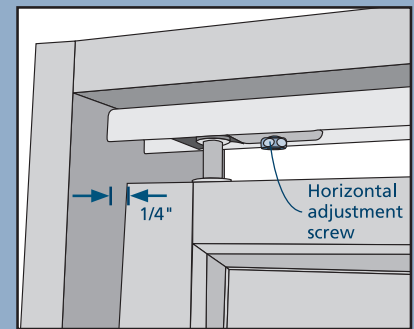
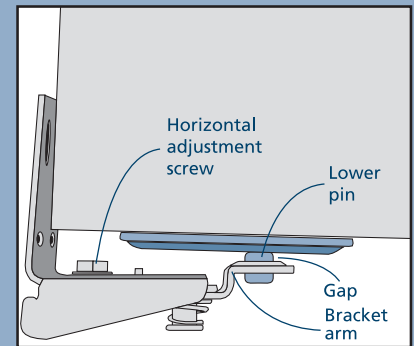

9. Loosen the screw on the snugger and close doors.

Move the snugger until it contacts the guide pin. Open doors and move the snugger an additional 1/8" toward doors and tighten screw. Doors should slightly "snap" shut, but reopen easily with a tug on the knob.

**SKIP to section 8. "COMPLETE INSTALLATION."**

## 5. INSTALLATION FOR TYPE C

### PARTS INCLUDED

- |                      |                      |
|----------------------|----------------------|
| A. Upper pivot pin   | F. Lower bracket     |
| B. Hanger with T-nut | G. Adjustment wrench |
| C. Snugger           | H. Track             |
| D. Top pivot bracket | Screws (not shown)   |
| E. Lower pivot pin   |                      |

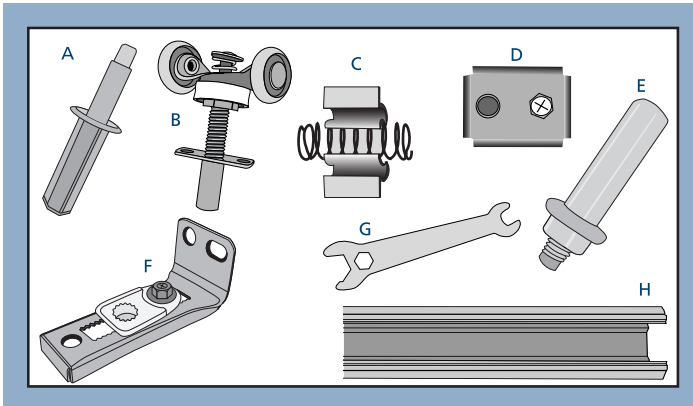

- If holes are not drilled in panels, pre-drill one hole on each outside corner of the assembly  $7/16"$  in diameter and at least  $1\frac{1}{2}"$  deep in the locations shown.
- Tap pivots into holes with light hammer blows as shown. Secure T-nut by driving a  $\#8 \times 1"$  pan head screw through both holes.
- Trim track to fit finished opening if necessary.
- Insert the hanger into one end of the track.  
Loosen the screw on the top pivot bracket and position on track with the screw toward the jamb. Snap the snugger onto the track next to the hanger, opposite the top pivot bracket as shown.
- Secure the track to the head jamb with the provided  $\#8 \times 1"$  pan head screws through the pre-drilled holes. Move the top pivot bracket back toward the track end until it is  $1/4"$  from the jamb and tighten the screw.

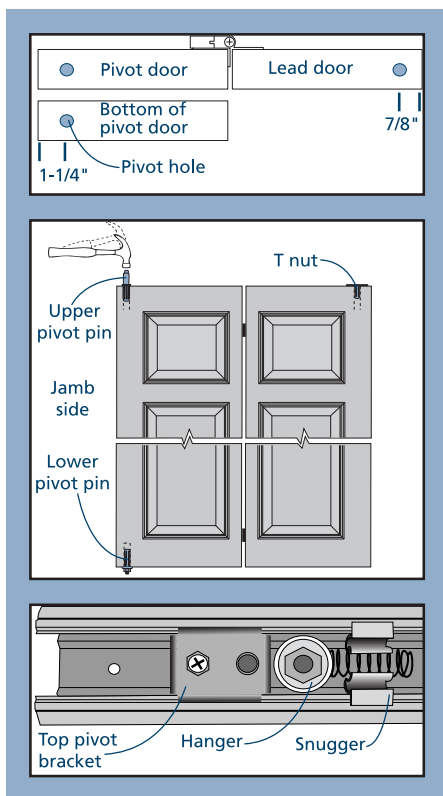

- Position the lower bracket in the jamb, centered with the track, and secure with the provided  $\#8 \times 3/4"$  flat head screws.
- Fold the door assembly and position the T-nut to the hanger. Using the provided wrench, screw hanger into T-nut as far as possible.
- Place the upper pivot pin into the hole in the top pivot bracket. Lift the assembly and place the lower pivot pin into the hole in the lower bracket. If installing a four-door system, repeat for the other assembly. Check positioning and operation.

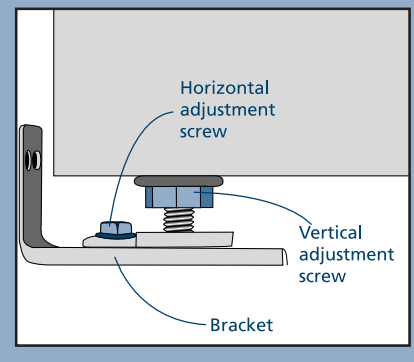
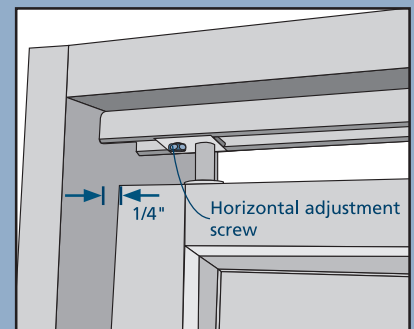
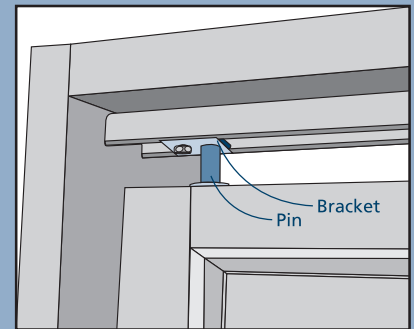
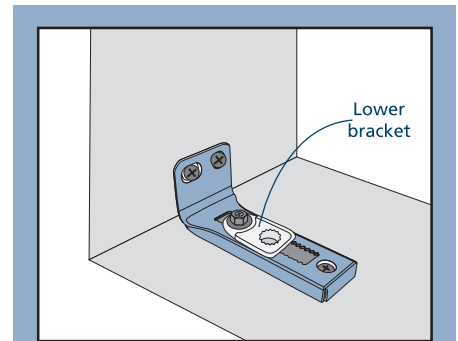

Verify there is a  $1/4"$  clearance between the pivot door and the jamb. Four-panel assemblies should be snug at the middle. If adjustments are necessary, door panels should be folded to gain access to the adjustment screws.

#### To adjust horizontally:

- At the top, loosen the screw in the top pivot bracket and move toward or away from the jamb until there is  $1/4"$  clearance. Re-tighten.
- At the bottom, loosen the adjustment screw and move toward or away from the jamb until doors are plumb with jamb, then re-tighten the screw.

#### To adjust vertically:

- Lift assembly slightly and rotate the adjustment screw to the right to raise doors, and to the left to lower them.
- Slide the snugger until it is against the jamb opposite the top pivot bracket, or place between hangers in four door sets.

SKIP to section 8. "COMPLETE INSTALLATION."

## 6. INSTALLATION FOR TYPE D

### PARTS INCLUDED

- |                    |                      |
|--------------------|----------------------|
| A. Upper pivot pin | F. Lower bracket     |
| B. Guide for track | G. Aligner           |
| C. Snugger         | H. Track             |
| D. Knob            | I. Adjustment wrench |
| E. Lower pivot pin | Screws (not shown)   |

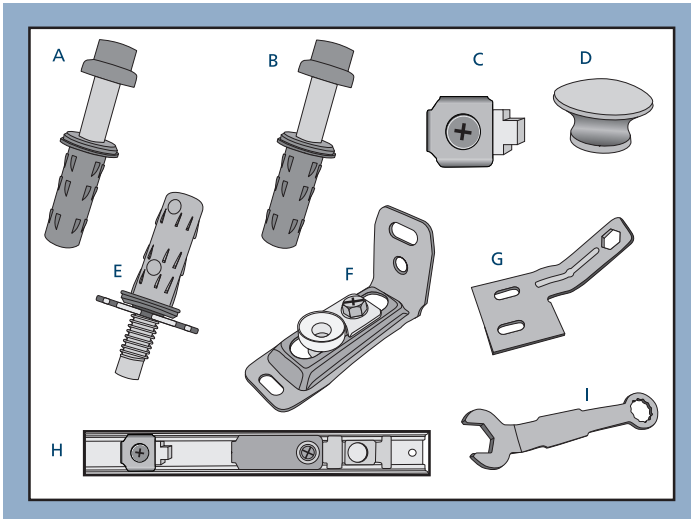

1. If holes are not drilled in panels, pre-drill 7/16" in diameter holes at least 1-3/8" deep, 1-1/4" from edges as shown. Tap pivots into holes with light hammer blows as shown.
2. Trim track to fit finished opening length if necessary.
3. Secure the track to the head jamb with the provided #8 x 1" pan head screws through the pre-drilled holes.
4. Position the lower bracket in the jamb, centered with the track, and secure with the provided #8 x 3/4" flat head screws.

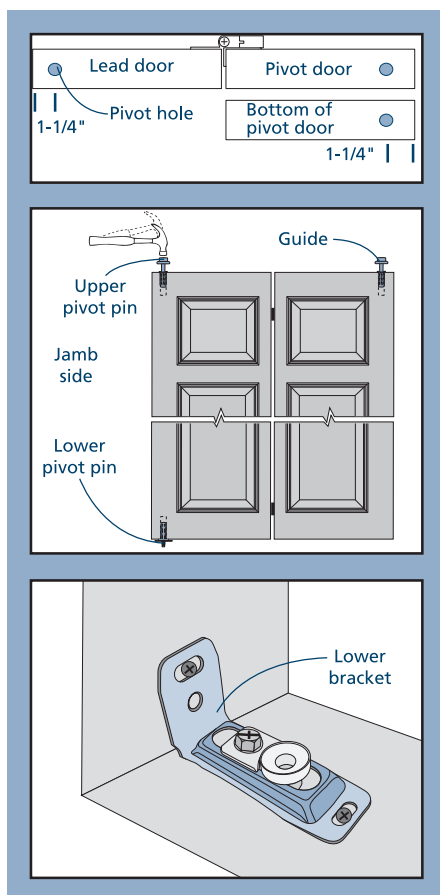

5. Place the upper pivot pin into the hole in the top pivot bracket and the guide pin into the track. Lift the assembly and place the lower pivot pin into the lower bracket. If installing a four-door system, repeat for the other assembly. Check positioning and operation.

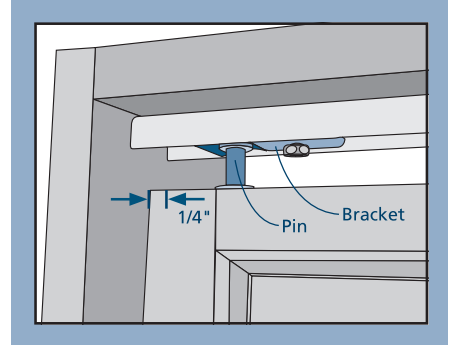

Two and four-panel assemblies should have 1/4" clearance between the pivot doors and each jamb. Four-panel assemblies should be snug at the middle.  
Door panels should be folded to gain access to the adjustment screws. In some cases, the doors may need to be removed to properly access the adjustment screws.

To adjust horizontally:

6. At the top, loosen the screw in the top pivot bracket and move toward or away from the jamb until there is 1/4" clearance. Re-tighten.
7. At the bottom, loosen the adjustment screw and move toward or away from the jamb until doors are plumb with jamb, then re-tighten the screw.

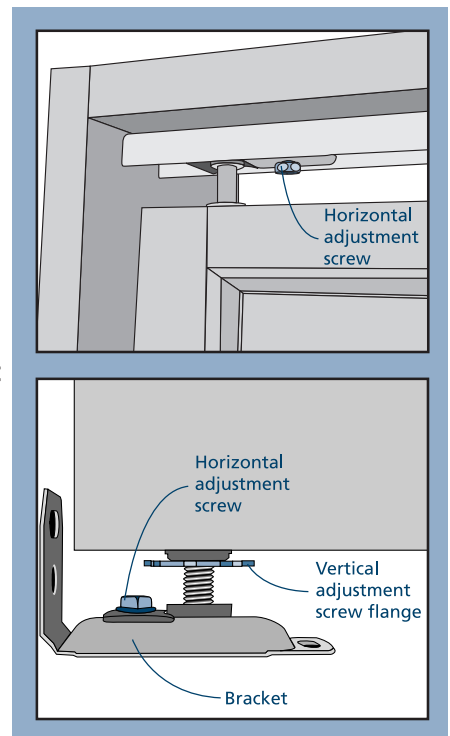

To adjust vertically:

8. Lift assembly slightly and rotate the adjustment screw flange to the right to raise doors, and to the left to lower them.
9. Loosen the screw on the snugger and close doors. Move the snugger until it contacts the guide pin. Open doors and move the snugger an additional 1/8" toward doors and tighten screw. Doors should slightly "snap" shut, but reopen easily with a tug on the knob.

SKIP to section 8. "COMPLETE INSTALLATION."

## 7. INSTALLATION FOR TYPE E

### PARTS INCLUDED

- |                          |                      |
|--------------------------|----------------------|
| A. Upper pivot plate (2) | G. Top pivot bracket |
| B. Hanger                | H. Aligner           |
| C. Snugger               | I. Track             |
| D. Knob                  | J. Adjustment wrench |
| E. Lower pivot pin       | Screws (not shown)   |
| F. Lower bracket         |                      |

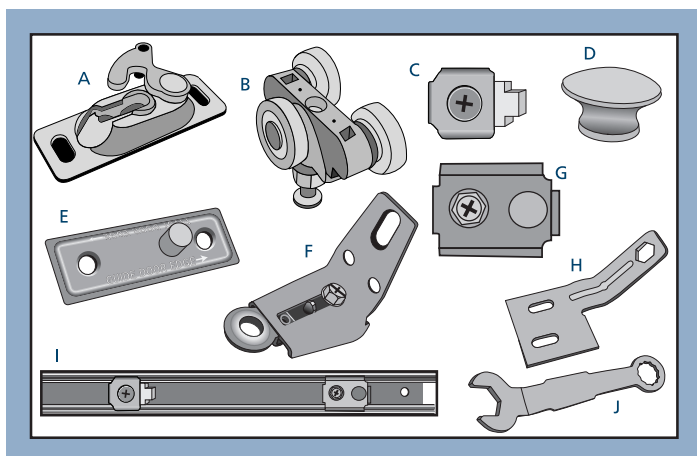

1. Fasten the pivot plates to each door panel with the 1-1/4" pan head screws in the locations shown. Use the 1" flat head screws on the lower pivot pin. Center each plate on the panel.

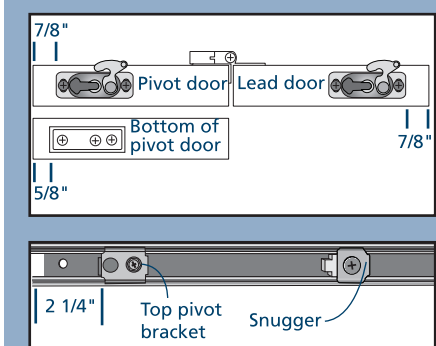

2. Trim track to fit finished opening.
3. Install top pivot bracket into one end of the track with the pin toward the end and 2-1/4" in. from the other end, install the hanger and snugger (with rubber bumper toward hanger) into track.
4. Position overhead track in the opening with the open side down and the bracket end toward the jamb. Allow 3/4" between the front of the opening and the track and drive the provided 1-1/4" pan head screws through the pre-drilled holes until snug. Position the lower bracket on the floor in line with overhead track. Fasten to the jamb with a 1-1/4" flat head screw through the middle of the top slotted hole.

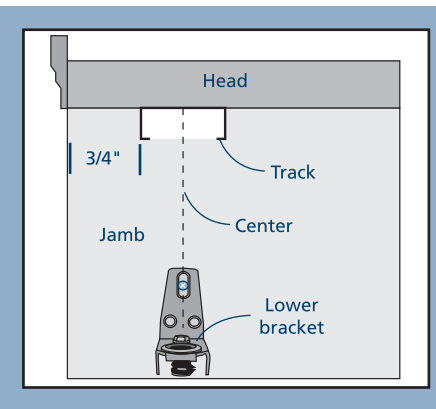

5. Unlock the track pivot plate by pulling the latch away from the bracket. With the door assembly folded, place the pin from the top pivot bracket into the pivot plate on the pivot door. Slide the pin into the pivot plate and slide the latch to lock the pivot plate to the bracket. Verify the pin is secure. In the same manner, lock the hanger into the pivot plate on the lead door.

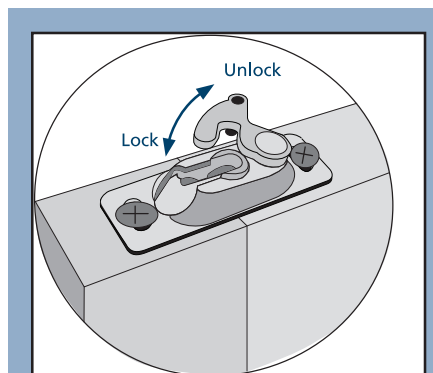

6. On the bottom, depress the arm on the lower bracket and insert the lower pivot pin.

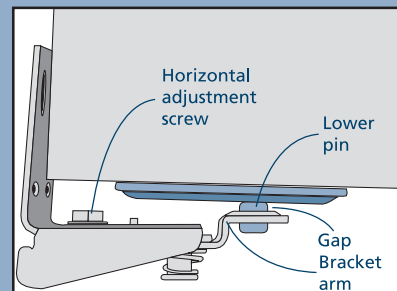

#### To adjust horizontally:

7. At the top, loosen the screw in the top pivot bracket and move toward or away from the jamb until there is 1/4" clearance. Re-tighten. Repeat the process for the lower bracket.

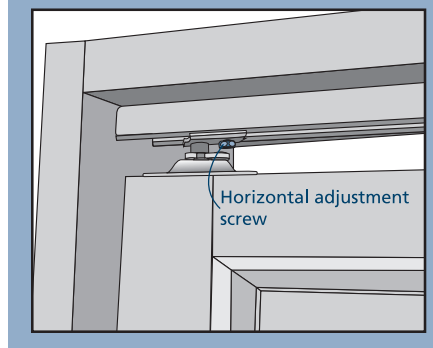

#### To adjust vertically:

8. There should be a slight gap between the lower pin and the bracket. If there is no gap or the gap is too large and allows the pin to come out of the bracket, loosen the single screw in the bracket and adjust up or down until there is a small gap and the pin is engaged in the bracket. When the bracket is properly adjusted, install the remaining two screws and tighten.
9. Loosen the screw on the snugger and close doors. Move the snugger until it contacts the guide pin. Open doors and move an additional 1/8" and tighten screw. Doors should slightly "snap" shut, but reopen easily with a tug on the knob.
10. Adjust the snugger by closing doors, loosen screw and slide against guide in track. Open doors and move snugger 1/8" closer to panels and tighten screw.

SKIP to section 8. "COMPLETE INSTALLATION."

## 8. COMPLETE INSTALLATION

For four-door configurations, mount an aligner as shown on the back side of each lead door.

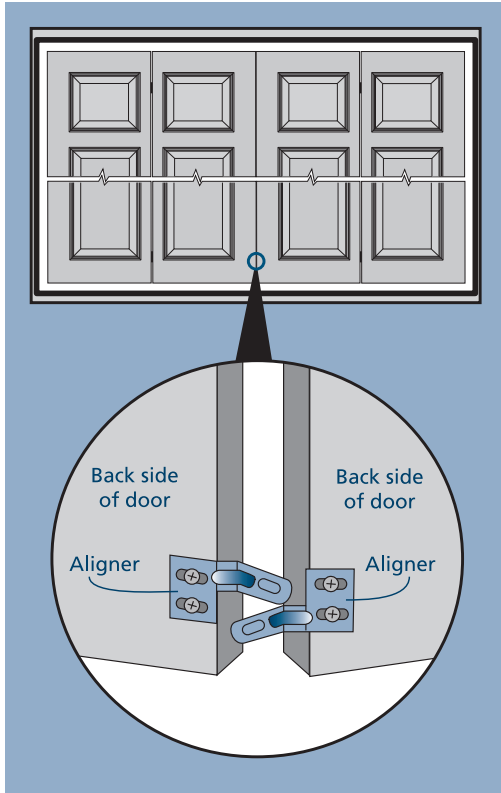

For best operational performance and aesthetic appeal, install the door knob in the center of the middle rail of the lead door(s) (panel without pivot hardware).

The knob, however, can also be installed in any other location

on the lead door if desired. Drill a hole slightly smaller than the screw and attach knob.

**Note:** Unless drilling the knob attachment hole close to an edge on a hollow-core door, it will likely be in a hollow part of the door. This does not cause problems and the door material is sufficiently strong if the screw is snug but not over tightened.

